

Fosroc® Conbextra TS

constructive solutions

High-flow, non-shrink, aggregate filled cementitious grout conforming to the requirements of BS EN 1504-3 Class R4

Uses

Conbextra TS is used for free flow, non-shrink, cementitious grouting for gap thicknesses 75 to 500 mm. Recommended applications include:

- Stanchion baseplates where a large gap is present
- Joints between pre-cast concrete panels
- Filling box sections

Advantages

- Non-shrink
- High strength
- Chloride free
- Can be pumped or poured
- Suitable for thick sections

Description

Conbextra TS is supplied as a ready to use dry powder. The addition of a controlled amount of clean water produces a free-flowing grout for gap thicknesses 75 - 500mm. In addition the low water requirement ensures high early strength and long-term durability.

Conbextra TS is a blend of Portland cements, graded fillers, selected aggregates and chemical additives. The filler grading produces a highly flowable grout which will not segregate or bleed and reduces the exothermic heat generation and risk of thermal cracking common with gap thicknesses in excess of 100 mm.

Specification clause

All grouting of gap thicknesses 75 - 500 mm shall be carried out using Conbextra TS, a pre bagged single component cementitious material which conforms with the requirements of BS EN 1504-3 class R4.

It shall be mixed with clean water to the required consistency and not exhibit bleed or segregation

A volumetric expansion of up to 1% shall occur while the grout is in a plastic state by means of a gaseous system.

The compressive strength of the grout must exceed 40 MPa at 7 days and 60 MPa at 28 days.

The storage, handling and placement of the grout must be in strict accordance with the manufacturer's instructions

Standards compliance

Conbextra TS complies with classification R4 according to BS EN 1504-3.

CE	
Fosroc Ltd, Drayton Manor Business Park, Coleshill Road, Tamworth, Staffs, B78 3TL 09 0370-CPD-0845	
EN1504-3 Concrete repair products for structural repair CC mortar based on hydraulic cement)	
Compressive strength	Class R4 (≥45 MPa)
Chloride ion content	≤ 0.05%
Adhesive bond strength	≥ 2.0 MPa
Adhesive bond strength after freeze thaw thermal cycling	≥ 2.0 MPa
Carbonation resistance	$d_k \leq$ control concrete
Elastic modulus in compression	≥ 20 GPa
Reaction to fire	Class A1
Dangerous substances	Complies with 5.4

Fosroc® Conbextra TS

Properties

The following results were obtained at a water : powder ratio of 0.132 and a temperature of 20°C unless otherwise stated.

Test method	Standard	EN 1504 Requirement	Result
Compressive Strength	EN 12190:1999	Class R4 \geq 45 MPa	@ 1 Day 14 MPa @ 7 Day 42 MPa @ 28 Days 70 MPa
Bond strength by pull off:	EN 1542:1999	Class R4 \geq 2.0 MPa	2.7 MPa
Chloride ion content:	EN 1015-17:2000	Class R4 \leq 0.05%	0.02%
Freeze thaw cycling:	EN 13687-1:2002	Class R4 \geq 2.0 MPa	2.4 MPa
Resistance to carbonation d_k	EN 13295:2005	Class R4 \leq ref concrete	Conforms
Fire rating	EN 13501-1	-	Class A1 Non-Combustible
Flexural strength	BS 6319 Pt 3:1990	-	6.7 MPa @ 28 days
Setting time	BS 4551 Pt14:1980	-	Initial set: 6 hours
Fresh wet density	-	-	Nominally 2300 kg/m ³
Alkali reactive particles	Method TI-B 52	-	\leq 1.0 vol %
Grout consistency / Water addition	-	-	3.3 litres water/ 25kg bag
Minimum thickness	-	-	75mm
Maximum thickness	-	-	500mm

Clarification of property values: The typical properties given above are derived from laboratory testing. Results derived from field applied samples may vary.

Application instructions

Preparation

Foundation surface

The substrate surface must be free from oil, grease or any loosely adherent material. If the concrete surface is defective or has laitance, it must be cut back / scabbled to a sound base. Bolt holes or fixing pockets must be blown clean of any dirt or debris.

Pre-soaking

For a minimum of 2 hours prior to grouting, the area of cleaned foundation should be flooded with fresh water. Immediately before grouting takes place, any free water should be removed. Particular care should be taken to blow out all bolt holes and pockets. Where water soaking is impossible contact Fosroc Technical Service.

Base plate

It is essential that this is clean and free from oil, grease or scale. Air pressure relief holes should be provided to allow venting of any isolated high spots.

Levelling shims

If these are to be removed after the grout has hardened, they should be treated with a thin layer of grease.

Formwork

The formwork should be constructed to be leakproof as Conbextra TS is a free-flowing grout. This can be achieved by using foam rubber strip or Silicone Sealant 33HM beneath the constructed formwork and between joints.



Fosroc® Conbextra TS

In some cases it is practical to use a sacrificial semi-dry sand and cement formwork. The formwork should include outlets for the pre-soaking water.

The unrestrained surface area of the grout must be kept to a minimum. Generally the gap width between the perimeter formwork and the plate edge should not exceed 150 mm on the pouring side and 50 mm on the opposite side. There should be no gap at the flank sides.

Mixing

Water addition: 3.3 litres per 25 kg bag

For mixing quantities up to 50 kg, a Bosch (or equivalent) 1150 watt, 280 to 640 rpm, 110 volt drill, fitted with a Conbextra mixing paddle is suitable.

For best results a mechanically powered grout mixer should be used. Larger quantities will require a high shear vane mixer. Do not use a colloidal impeller mixer.

It is essential that machine mixing capacity and labour availability is adequate to enable the grouting operation to be carried out continuously. This may require the use of a holding tank with provision for gentle agitation to maintain fluidity.

Prior to the first mix the vessel should be wetted and drained. The selected water content should be accurately measured into the mixer. Slowly add the total contents of the Conbextra TS bag, mix continuously for 5 minutes, ensuring a smooth, even consistency is obtained.

Placing

Place the grout within 20 minutes of mixing to gain the full benefit of the expansion process.

Conbextra TS can be placed in thicknesses 75 to 500 mm in a single pour.

For thinner sections use Conbextra HF grout.

Any bolt pockets must be grouted prior to grouting between the substrate and the base plate.

Continuous grout flow is essential.

Example of a typical hopper system:

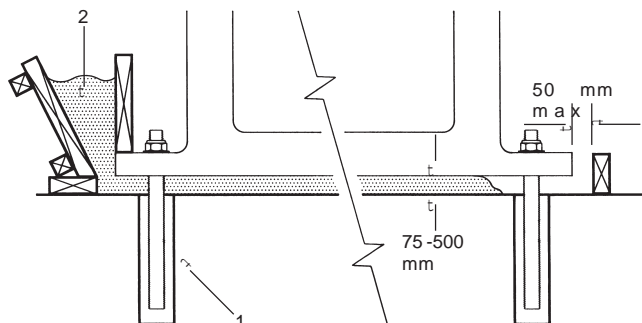

- 1 Conbextra GP or Lokfix* (first stage)
- 2 Conbextra TS poured or pumped into removable hopper (second stage)

* Also available from Fosroc.*

Sufficient grout must be available prior to starting, and the time taken to pour a batch must be regulated to the time taken to prepare the next one.

The mixed grout should be poured only from one side of the void to eliminate the entrapment of air or surplus pre-soaking water. This is best achieved by pouring the grout across the shortest distance of travel. The grout head must be maintained at all times so that a continuous grout front is achieved.

Where large volumes have to be placed Conbextra TS may be pumped. Screw feed and piston pumps are suitable for this purpose.

When the Conbextra TS has reached trowelable consistency, the unrestrained portion should be cut back to the baseplate/bearing plate.

Curing

On completion of the grouting operation, exposed areas should be thoroughly cured with Concure WB curing membrane, continuous application of water and/or wet hessian.

Cleaning

Conbextra TS should be removed from tools and equipment with clean water immediately after use. Cured material can be removed mechanically, or with Fosroc Acid Etch.

Fosroc® Conbextra TS

Estimating

Supply

Conbextra TS is supplied in 25 kg bags.

Yield

Allowance should be made for wastage when estimating quantities required.

The approximate yield per 25 kg bag is 12 litres (0.012 m³)

Limitations

Low temperature working

When the air or contact surface temperatures are 5°C or below on a falling thermometer, warm water (30°C to 40°C) is recommended to accelerate strength development. Substrates should be free from ice.

For ambient temperatures below 10°C the grout consistency should be flowable and the formwork should be maintained in place for at least 36 hours.

Normal precautions for winter working with cementitious materials should then be adopted, specifically protecting the grout from freezing in the first 24 hours after placing.

High temperature working

At ambient temperatures above 35°C the mixed grout should be stored in the shade. Cool water (below 20°C) should be used for mixing the grout.

Storage

Store unopened bags in cool dry internal conditions. Conbextra TS has a shelf life of 12 months if kept in a dry store in sealed bags. If stored in high temperature and high humidity locations the shelf life may be reduced to less than 6 months.

Precautions

Health and safety

For further information refer to appropriate Product Safety Data Sheet available at www.fosroc.com

Fire

Conbextra TS is non-flammable.



Fosroc Limited
Drayton Manor Business Park
Coleshill Road, Tamworth,
Staffordshire B78 3TL. UK

www.fosroc.com

Important note

Fosroc products are guaranteed against defective materials and manufacture and are sold subject to its standard Conditions for the Supply of Goods and Services, copies of which may be obtained on request. Whilst Fosroc endeavours to ensure that any advice, recommendation, specification of information it may give is accurate and correct, it cannot, because it has no direct or continuous control over where or how its products are applied, accept any liability either directly or indirectly arising from the use of its products, whether or not in accordance with any advice, specification, recommendation of information given by it.

telephone:
+44 0 (1827) 262222

fax:
+44 0 (1827) 262444

email:
uk@fosroc.com



Certificate number FM 610